

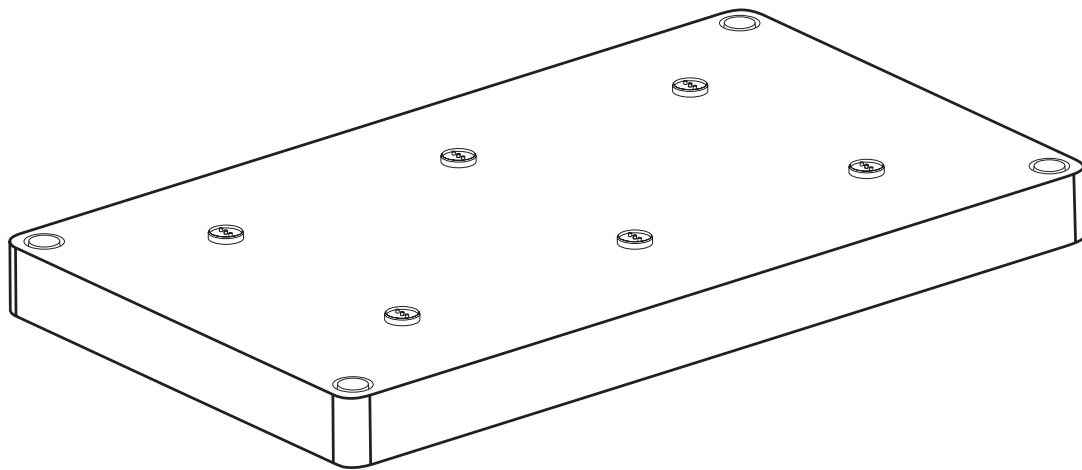

Multi-Contact Charging Shelf



Product Information

Multi-Contact Charging Shelf

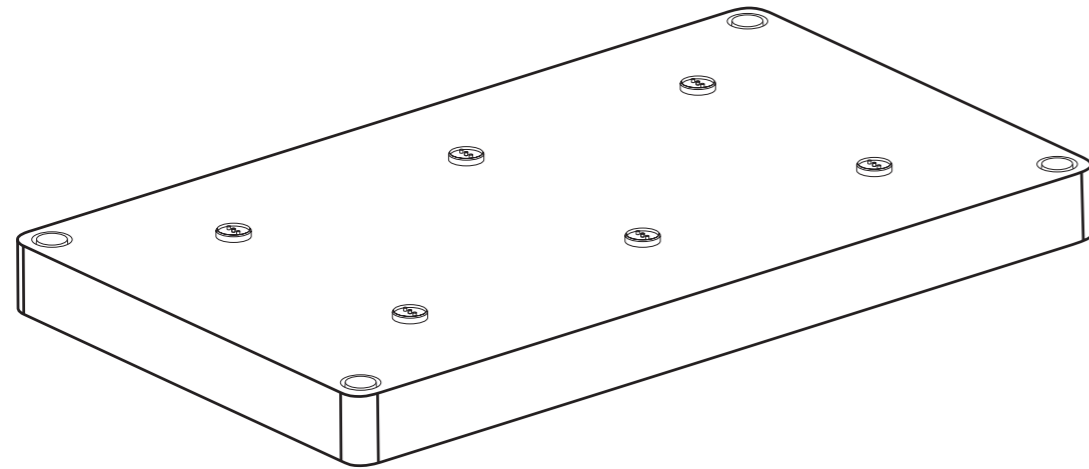

Product Description

Model H90000	Application Multi-Contact Charging Shelf	Net Weight 1.62Kg	Inner Box 275 x 60 x 540mm	Outer Carton 290 x 230 x 565mm	Pcs/Ctn 3
Input 24V, 2A	Output 5V, 1A (X6)	Safety Class CLASS III	Ingress Protection IP20		
Materials ABS plastic shelf with 6 electrical docks.					
These charging shelves are designed to be stackable in a tower configuration of up to four shelves, allowing you to efficiently charge a total of 24 LED Cordless lamps simultaneously while ensuring safe and effective charging. Suitable for professional use.					

AC-DC Adapter

Multi Contact Charging Shelf (6)

Stacking Posts

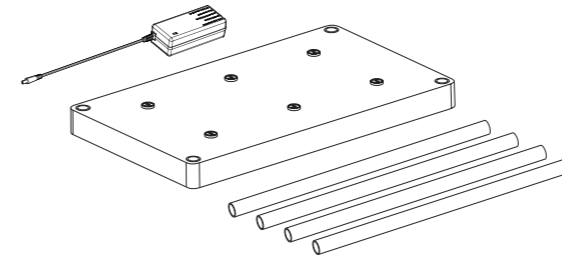

1

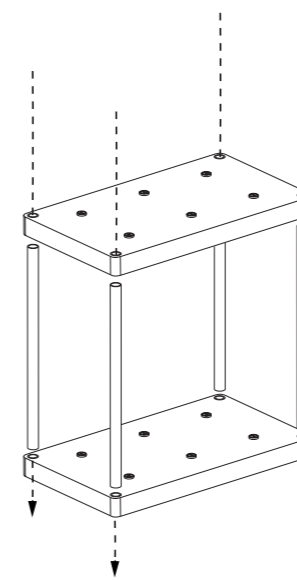

Use Power Adapter Cable Supplied

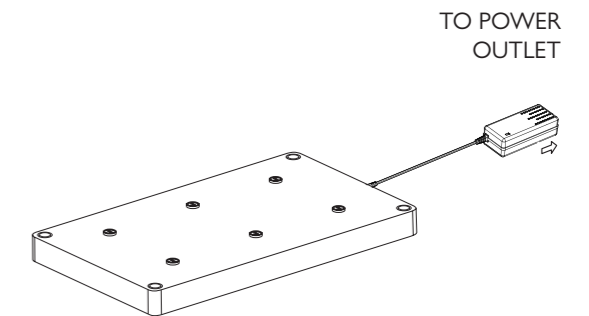

2

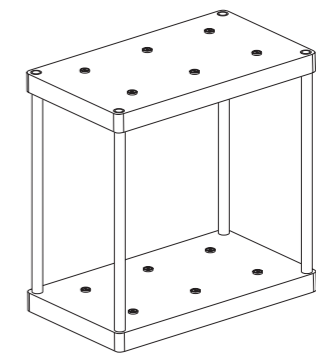

3

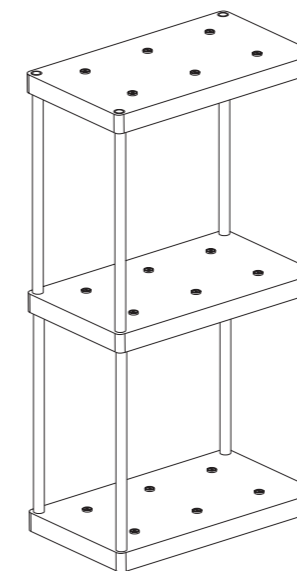

STACKABLE UP TO MAX 4 LEVELS

WHENEVER INSTALLING OR REARRANGING SHELVING, NEVER LIFT ASSEMBLED SHELVING.





utopia

Head Office & Showroom
Utopia Tableware
One Langham Park,
Mansfield Road,
Chesterfield, S41 0GG

T. 01246 858800
E. info@utopia-tableware.com

www.utopia-tableware.com
[/utopiatableware](#)
[@utopiatableware](#)

